



EUROPEAN FEDERATION OF RADIO OPERATED MODEL AUTOMOBILES

MEMBERS HANDBOOK 2018 



APPENDIX 1

1/8th and 1/10th SCALE I.C. TRACK CARS Combined

1. ALLOCATIONS FOR EUROPEAN CHAMPIONSHIPS.

- 1.1. The allocations for the EFRA European Championships 1/8th. and 1/10th. 200 mm scale will be established by the section meeting and published in the minutes.
- 1.2. For allocation and re-allocation procedures see Gen. 3.6. and 6.2.
For BOTH CLASSES: Allocations will only be offered for EC and WC events to those member countries that have written to request places.
- 1.3. All countries receive re-allocated places in the order of the Allocation-list, unless stated otherwise in this list.
- 1.4. The number of entries for EFRA European Championships is 120 with a maximum of 150. Accommodations for at least 120 drivers must be available. If the number of entries exceed 120, the accommodation must be sufficient for all participants.
- 1.5. Applications for all EC's must be done in writing by using the applications forms to be presented at the annual AGM section meeting.

2. RACING FORMAT EFRA EUROPEAN CHAMPIONSHIPS AND GRAND PRIX.

- 2.1. European Championships are held in following classes:
 - a) The European Championship Sportscars/GT-P/Group-C ECA and ECB will be held on the 4th weekend of July. The European Championship 1/10th Touring Car Sedan bodies ECA and ECB will be held on the 3rd weekend of August. In the year there is an IFMAR World Championship outside the EFRA Bloc, dates between EC and WC must be separated with at least 4 free weekends between the finals. In the years there is an IFMAR WC in the EFRA Bloc, there will be no EC-A (see schedule IFMAR, www.ifmar.org).
It will be open to 64 drivers in the following order: current World Championship (if European) in 1/8th IC on road and 1/10th 200mm IC, current European Championship in 1/8th IC and 1/10th 200mm IC, 25 EFRA A drivers and 35 drivers (or numbers of drivers necessary) to complete 64 allocations. 35 drivers will bump up in Controlled Time Practice during the event. One special EFRA medal will be awarded to the fastest driver under 17 year in each class. So, everybody of 16 years during the race dates, or younger can compete for this medal. One trophy must be awarded by the Organiser for each class.
 - b) The Euro B 1/8th Sportscars/GT-P/Group-C will be open to: All drivers who want to attend the race, except drivers who have been included in European Championship "A". The Euro B for 1/10th will be open for: All drivers who want to attend race except drivers who have been included in European Championship "A". For both classes: The winner of the B-EC will become EFRA 'A' driver immediately and will retain A-licence for 2 years.
 - c) The EFRA ranking list is based on the overall result of the EFRA GP Series. The total result of this list will decide upon A and B driver just before European Championship.
 - d) European Championship 1/8th Track 40+ and 1/10th 200 mm 40+. This will be one combined event. EC 40+: Open to all drivers of 40 years, including those who become 40 that year and older.
 - e) EFRA GP series. EFRA GP Series will be held in the first part of the year

(March-June). Minimum 2 and maximum 3 GP's will determine EFRA A and EFRA B drivers. The first 25 drivers will be EFRA A drivers, the rest of the drivers will be EFRA B drivers in the current year. EFRA GP series (1/8th and 1/10th 200mm) are run in combined events. EFRA GP meetings will use the points system, with the drivers best 2 meetings out of the 3 to count. If EFRA GP series is held with only 2 meetings, all the races will count. EFRA GP series will follow GP point system (see 3.3.6).

f) NATIONS CUP. At every European Championship A EFRA will hold a Nations Cup, with drivers competing as a team representing their countries. When race is over, the best two (2) drivers of each country will represent their country at this Nations Cup. Both results will be added together by points (according to the rule 3.3.6) and give the result of their National Team.

2.2. Free practice for an EC is only allowed from the Monday preceding the Race. It will not be allowed for competitors in the event to practice for 10 days before this Monday (see also Gen. 8.1.). For 1/8th and 1/10th due to A&B held at the same event: Pit lane refuelling may be forbidden during free practice at an EC if it is necessary to facilitate a quicker turn-around of drivers (every five minutes).

2.3. Free practice for Grand Prix events must be allowed at least from Friday preceding the event (see Gen. 8.2.).

2.4. General Qualifying format for EC's and GP's:

5 Rounds of Qualifying will be run, irrespective of the number of drivers. Qualifying is 4 minutes + last lap for 1/8th and 1/10th. A point system will be used to establish the qualifying result. The number 1 ranked driver after completion of the qualifying heats will move up directly to the main final and take the pole position on the starting grid. The drivers ranked 2nd to 5th will compete in a 'super-pole' final after completing the last Round of Qualifying.

Super-pole: Drivers ranked 2nd to 5th will drive the 'super-pole' individually on the track, for 6 consecutive laps including warm-up on controlled tyres. Procedure for Super Pole will be: 3 minutes warm up for each driver and then 6 consecutive laps. The 'super-pole' running order will be 5, 4, 3, 2. The driver that scores the fastest lap will also move up straight to the 'Main' Final and take the second position on the starting grid.

The other drivers from the 'super-pole' will start in the semi-finals as per qualifying ranking. Depending on time available all finals higher than 1/64th can be shorter than 20 minutes (for instance 10 minutes).

See also 2.6 The number of Rounds to count is as follows:

1 Qualifying Round completed	1 by laps and total time.
2 Qualifying Rounds completed	1 best by laps and total time.
3 Qualifying Rounds completed	2 best point scores to count.
4 Qualifying Rounds completed	2 best point scores to count.
5 Qualifying Rounds completed	3 best point scores to count.

Any Qualifying Round has to be completed for any Heats in that Round to be awarded points that count. Fastest competitor (based on laps & time) in each Round will score zero (0) points, second place 2 points, third place 3 points, fourth place 4 points etc.

If two (or more) competitors achieve an equal time in any Round they will be awarded equal points. The next competitor not included in the tie will be awarded points corresponding to his position in the particular Round.

(NOTE: drivers not recording a time or having a time disqualified in any Round score points for last place in that Round)

Overall Qualifying positions are decided by each driver 'best'(lowest) points

being added together, based on the number of Rounds to count as shown in above table. In the event of a tied position, the driver with the single highest finishing position in either of the best Rounds that counted will be awarded the tie (e.g. 1+3 = 4 beats 2+2 = 4). In the event of a continuing tie then the laps and times from the best points Round will be compared. The driver with the fastest laps and time will be awarded the tie. In the case of a continuing tie, then the times from the second best scores will be compared. Only counting Rounds will be used to decide Qualifying positions (or ties), all other Qualifying Round scores and times will be discarded.

If the intended maximum number of Rounds cannot be completed, due to weather or unforeseen circumstances, the number of Rounds to count will follow the same format as the table above.

Rain procedure: Only rounds ran under the same conditions will count. Same conditions means: no differences in average lap time by more than 20%. The Race director together with the referee will make the final decision.

- 2.5. The time schedule should not be rigid but adapted to the number of entrants. As a guideline at EC's with 100 or more entrants the schedule should be as follows:

Monday - Wednesday: Free or Controlled Practice

Wednesday & Thursday: technical inspection All cars must pass technical inspection before Controlled Timed Practice.

Thursday: Controlled Timed Practice and Qualifying 1 & 2 in the afternoon.

Friday: Qualifying Rounds 3 to 5, 'Super-pole' (for 2,3,4 and 5 Top Qualifiers), lower finals up to 1/64.

Saturday: 1/32 upwards, 1/16th, 1/8, 1/4 final; Practice 2 direct Qualifiers, 1/2 final, final.

For EFRA GP series as a guideline:

Friday: Free or controlled practice.

Saturday: Controlled time practice, Qualifying and "Super-Pole".

Sunday: Finals

The time schedule and the number of heats can be adjusted by the race director with agreement from the EFRA representative due to weather and unforeseen conditions and the number of total drivers at the event.

For EFRA European Championship, the race director should seed the Controlled Practice heats, Controlled Timed Practice heats based on the EC from last year.

For EFRA GP series, the race director should seed the Controlled Practice heats and Controlled Timed Practice heats according to last EFRA GP series meeting.

The heats shall contain a maximum of 10 drivers. These Controlled Practice heats will be of 10 minutes duration. The Controlled Timed Practice heat will be of 4 minutes duration. The ranking from controlled timed practice will be used to make the heats for the qualification heats. The schedule of all practice heats including each practice heat starting time will be carried out by the organisation of the event and it should be given to the Team Managers (only in EC) & published for general knowledge.

- 2.6. General format for sub-finals and main final at EC and GP:

The lower finals are 20minutes up to 1/64 finals. Time for all finals higher than 1/64th to be set at team managers meeting. The duration of the main final is 45 minutes.

Sub-finals: The best 3 in each sub-final move up to the next final.

Semi-finals: The best 3 in each semi-final move up to the main final, plus the best 2 remaining drivers from the 2 semi-finals combined. When racing

conditions are different in the two semi- finals, the best 4 of each semi-final move up to the main final.

Starting order for the drivers who moved up to the main final is based on number of laps and time for positions 3 to 10. In different circumstances it will be number 1 from the A semi-final who gets the number 3 and the number 1 from the B semi-final who gets the number 4 etc. Semi-final B is the first final to start on the Saturday afternoon.

After Practice direct Qualifiers'cars (TQ and Super Pole winner), both cars must be put in Parc Fermé. Also, after the first semi-final all cars will be put in Parc Fermé in technical inspection and they will be released after completion of the technical inspection of the 2nd semi-final. This will give all drivers that proceed to the final equal time for preparation.

2.7 During the race 2 (two) mechanics are allowed in the pit lane.

2.8 When the Qualification has been completed, the TQ, winner of super-pole and the drivers of car number 1 of Semi A, and car number 1 of Semi B must do a press interview with the cars (not only with the body) in a place that the organiser must prepare on the track. This place must be equipped with a table with an EFRA MEMBERS banner and chairs for the drivers. The EFRA official media partner will have preference for the first 5 questions. When the main final has been finished, we will have the same procedure for the 3 first drivers in the final, when the result has been declared official for the race director.

3. TRACK SPECIFICATIONS

3.1. Track surface should be unsealed asphalt or coarse finish with any joints smoothed.

3.2. Minimum length must be 200 metres (advised 240-300 m.).

3.3. Minimum width of the track will be 4 m. between marking lines. (advised for new tracks 4 m between the marking lines). The maximum width is 6.50 m. The marking lines must be 8-10 cm wide and either white or yellow. They must be approximately 20 cm away from the edge of the racing surface.

3.4. Maximum distance from the middle of the drivers rostrum to the furthestmost point of the track must be 60 metres.

3.5. Vision: no obstacles may interrupt the vision from the driver's rostrum to any part of the track.

3.6. A broken line may be drawn in the middle of the straight to aid vision. No lines may be drawn in corners other than the outer marking lines.

3.7. The refuelling and pit area should be clearly distinguishable from the main track and as close as possible to the drivers' rostrum. Exit from and entrance to the main track is advised to be on a slow part of the track.

3.8. Track design must include both right and left hand turns and must have a straight of minimum length 45 metres.

3.9. Outside barriers must provide a positive means of stopping a car which misses a corner or runs out of control. The primary consideration for selection of the outside barriers shall be the protection of the spectators and not the cars.

3.10. Inside barriers must deter corner-cutting and prevent cars reaching other parts of the track. Inside barriers must be positioned and dimensioned to prevent cars from flying over the outside barrier into the public enclosures. The barriers must be smooth. When cones or dots are used, they should not be higher than 5 cm.

3.11. Barriers must be a minimum of 20 cm away from the marking lines on the track.

3.12. The inner and outer surrounds to the track must be of grass or other suitable materials such as concrete. The object of these surrounds is to slow down any

car that leaves the racing surface. The car must be able to leave the infield or outfield unassisted to minimise the need for Marshall's assistance. Marshal posts must be positioned at 30 m intervals around the track. They may not obstruct vision of the drivers. The post must be numbered. When a post is located at a dangerous part of the track (i.e. the straight or a fast corner) this post must have protection for the marshal (a wall, tyres, a gate, etc.).

3.13. A start/finish line must be painted across the track, preferably in front of the time keeping position. The first start line box must be located more than 10 m. away from the following corner.

3.14. Only a Le Mans type of start will be used. For Le Mans type of starts, 10 numbered boxes will be located on the edge of the track, at an angle of 20-45 degrees to the track, min. 2 m. and max. 4 m. apart. The boxes must be 70-100 cm long and 30-40 cm wide (see 3.14.).

4. RACE PROCEDURES 1/8 & 1/10:

4.1: CONTROLLED PRACTICE AND CONTROLLED TIMED PRACTICE PROCEDURES for all EFRA races:

All practice in EFRA races will be defined with the best result of 3 consecutive laps of the driver. The result will be used in the following procedure:

For EFRA GP series: The race director should seed Controlled Practice and Controlled Timed Practice according to the last meeting of the EFRA GP series. Controlled Practice shall contain a maximum of 10 drivers. These Controlled Practice heats will be of 10 minutes duration. The Controlled Timed Practice will be of 4 minutes duration. The arrangements of the Qualifying heats and the numbering will be defined with the best result of 3 consecutive laps of the Driver, made during 2 controlled timed practice runs.

For EC's: The race director should seed Controlled Practice and Controlled timed Practice according to the EC from last year. Controlled Practice shall contain a maximum of 10 drivers. These Controlled Practice heats will be of 10 minutes duration. The Controlled Timed Practice will be of 4 minutes duration. The results of the Controlled Timed Practiced will determinate allocations to participate in the EC A. This ranking list will not consider drivers who are classified directly in the EC A (25 first drivers for EFRA GP series, current WC 1/8th if European, current WC 1/10th if European, current EC 1/8th and current EC 1/10th). The total amount of drivers for EC A will be 64. Rest of the drivers will race in EC B.

The drivers must stand adjacent to their numbers on the rostrum; the mechanics must remain in their boxes along the pit lane. For all finals, drivers with the lowest starting numbers may choose their position on the rostrum and the mechanics must stand under the driver where this is possible or in the same order.

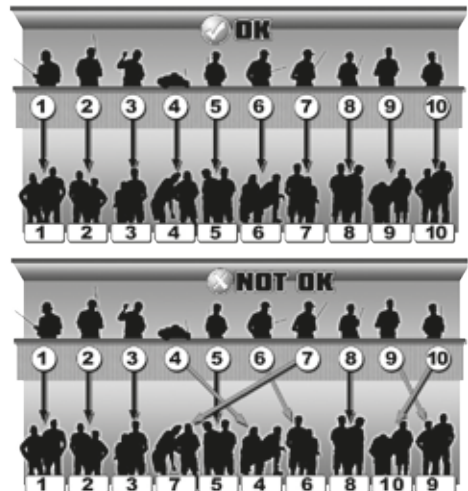

4.2. STARTING PROCEDURE OF HEATS

Starting for qualifying heats will be from the start line or pit lane, using the staggered start system (one by one). In each Round, the order of starting Heats will be as follows:

Round 1-- 1,2,3,4,5,6,7,8,9,10

Round 2-- 4,5,6,7,8,9,10,1,2,3

Round 3-- 7,8,9,10,1,2,3,4,5,6

Round 4-- 10,9,8,7,6,5,4,3,2,1

Round 5-- 6,5,4,3,2,1,10,9,8,7

4.3. Qualifying.

All Qualifying runs and Finals are run by "time plus completion of lap" system. Qualifying heats are 4 minutes duration. For duration Lower Finals and Main Final see 2.6. The use of a personal transponder is mandatory.

When the time is over, an audible signal is given. A car finishes when it passes the finish line after the finish-signal is given. The car must immediately return to the pits and may not hinder other cars still racing.

In case of doubt (on the finish-line when time is over), a car may race one more lap and finish. Whether he finishes or not when time was completed, is up to the Time-keepers and cannot be disputed.

After returning to the pits, the engine must be stopped immediately and the transmitter turned off and impounded if needed.

4.4. Qualifying, staggered start system:

Qualifying, staggered start system:

1. There must be a minimum 3 min. gap between the end of one heat and the start of the next heat. Also, a minimum of 2 minutes must be allowed between the issuing of the transmitters and the start of the heat.
2. An audible warning will be given at 1 minute and again at 30 seconds prior to the official start, in English and other languages as appropriate.
3. From 30 seconds until 3 seconds the cars must be held at the starting boxes (this could also be the pit lane). If a car is not at the starting box at 3 seconds (due to unforeseen problems) the car may start from the pit lane after other cars have officially started. The race director and referees will monitor for the abuse of this procedure.
4. Cars are released in the right order for the Round by the starter.

4.5. RAIN PROCEDURE DURING QUALIFYING:

1. The Race Director and the Referees are jointly responsible for the decision to stop a race in the event of rain.
2. On the result sheets the Race Director or the appointed official must mark a heat 'WET' when the heat was raced under wet conditions (20% differences in lap times). On the corresponding record sheets, this must also be marked. The Race Director together with the Referees will decide in case of any doubt. Heats are generally considered to be 'WET' when there is any rain or moisture on the track and it is obvious to the Race Director that the cars cannot perform to their maximum capability. The Race Director may decide to postpone qualifying if it is likely that qualifying can be resumed within reasonable time.
3. Due to the points system and when weather and time permits, the Race Director must try to complete as many Rounds as possible under equal circumstances.
4. When continuation is judged to be senseless, or when other drivers should be offered a fair chance to drive under dry conditions, the Race Director

together with the Referees may decide to end a heat or cancel a complete heat. (4.8.1.).

5. When 1 Round is finished under dry conditions, the Race Director can postpone the qualifying until the track is declared fully dry again. If it is likely that this will interrupt the qualifying for more than 1 hour, the Race Director may decide to open the track for controlled practice.
 6. In case of interruption due rain situation when a round of qualification is running, all this ROUND of qualification will be discarded.
 7. When race director declares the race to be wet, a second car can be used as a rain car in same conditions like in sub-finals and final (see 4.8).
- 4.6. Qualification Order and Finals.
1. After all Qualifying Rounds have been completed the Qualification order is established, by taking the total counted points result of each driver.
 2. In case of more than one driver recording identical best results of qualifications the next best result is taken.
 3. In the case of more than one driver recording identical results in a Final, the driver starting with the higher start number is classified as the faster, e.g. if number 5 and 2 have equal times, 5 is deemed to have the higher final placing.
 4. The Sub-Finals and Main Final are run according to the schedule printed in the official race program, which may only be changed by a team managers majority vote.
 5. After all Sub-Finals and Main Final are completed, a final result list is prepared based on laps and time, bearing in mind the Sub-Final order. In case of rain see 4.7.=
- 4.7. STARTING FOR SUB-FINALS AND FINAL

Starting for sub-finals and final will be on a 'Le Mans' type grid, with the faster Qualifier starting in front of the slower. Finals, Le Mans start grid:

1. There must be a minimum 3 min. gap between the end of one final and the start of the next final. Also, a minimum of 2 minutes must be allowed between the issuing of the transmitters and the start of the final.
2. An audible warning will be given at 1 minute and again at 30 seconds prior to the official start, in English and other languages as appropriate.
3. From 30 seconds until 3 seconds the cars must be held at the starting boxes. If a car is not at the starting box at 3 seconds (due to unforeseen problems) the car may start from the pit lane after other cars have officially started. The race director and referees will monitor for the abuse of this procedure.
4. For all finals, from 10 seconds until 3 seconds prior to the start, a second by second countdown will be made in English.
5. For Le Mans Grid Starts: at 5 seconds prior to the start, the Starter will lower the starting flag and at 3 seconds the flag will be fully down. At this point, all cars must be released by the mechanics, who will all step back 1 meter. The cars must remain in the boxes, no part of the car touching the starting line.
6. From 3 seconds; the verbal count-down stops and the actual start-signal will be given by the Starter after a period of between 0 and 5 seconds has elapsed. If the grid is not to the satisfaction of the Starter, he may require a restart, re-commencing with the count-down from 30 seconds.
7. The official start signal will be audible by means of a 'hooter' (computer operated signal), operated by the Starter/Timekeeping supervisor. This

signal will also start the Timing Systems.

8. Jump-starts, (i.e. any part of the car touching the starting line) will be penalised with a 'STOP and GO' penalty. The time for this 'STOP and GO' has to be set at the team managers meeting before the actual race starts and will have a maximum of 10 seconds. This penalty is issued by the Starting Official, Race Director or the Referee and must be announced immediately after the start. The penalty will be marked on the result-sheet.
9. Under no circumstances will the race be stopped due to a jump-start.
10. The Starter may only interrupt the race and make a restart in the event that he considers the starting procedure, or the start was not carried out correctly.
11. Delayed start: Providing the starter has not called 30 seconds (the trial lap, see 4.3 is part of the procedure after 30 seconds) for the cars to the start line, any participant of the semi-final and final may request a delay of 10 minutes to carry out repairs on his car. This delay can be granted only once for each semi-final and the final. The track is closed, if the delay is requested as a result of frequency or radio problems. The track is open, if the delay is requested for mechanical repairs or problems. Any driver asking for a delay will start from the end of the grid (11th position to be painted on the track) or from the pit lane in case he is not within time at the grid.

4.8. RAIN PROCEDURE Sub-Finals:

In case of different weather conditions during Sub-Finals, the final classification will be as follows: Place 4 of Sub-Final A and Place 4 of Sub-Final B will both be awarded place 11th equal in the general classification. Place 5 of Sub-Final A and place 5 of Sub-Final B will both be awarded place 13th equal in the general classification and so on...

WET CAR: When a race director declares the race to be wet, a second car can be used as a rain car. This car cannot be used (shared) by another driver/s in the same event. The rain car has to be scrutinised and be visibly marked as a rain car in due time before it is used. One rain car cannot be marked for several drivers. Multiple marking of the chassis is not allowed. Removing of existing marks to mark the chassis for another driver is not allowed and will be seen as violation of existing regulations. This rain car can only be used in wet conditions and not in dry conditions. This car cannot be used when the heat or final has already started. Once you start (in time) with a rain car you must finish with this rain car.

4.9. RACE INTERRUPTIONS:

1. In the case of a race which is interrupted for more than 60 minutes for reasons beyond the control of the organisers (bad weather conditions with safety risks for all persons at the meeting), the referees together with the Race-director will decide whether to cancel or continue the meeting.
2. In the case of an interruption of a heat the entire heat will be re-run.
3. In the case of an interruption of a sub-final or main final the following procedure will be used:
 - A. If less than 10 minutes of a final has been run, the results will be cancelled, and a new start given for the total time of the final. Vehicles may be repaired before the new start.
 - B. If more than 10 minutes of the final have been run, the results at the moment of the interruption will be kept. The new start will be given for the time which remains to complete the final. Vehicles may not be repaired before the new start. The two results will be added to give the final and definitive placing. If the second start cannot be made

for any reason, the results from the first part will be used as the final and definitive placing.

- C. When the interruption takes place after 75% or more of the race is past, the results as at the time of the interruption becomes the final result. At the moment of the interruption of the race, the drivers will leave their vehicles on the start-line under the control of the Race Director. They may switch off the radio and stop the engine. There will be no repairs carried out to the vehicle or changing of tyres. Any driver who does not observe this rule will be immediately disqualified.

5. GENERAL TECHNICAL SPECIFICATIONS

All measurements referred in this appendix are minimum or maximum values. All measurements for the motor dimensions to be considered with 2 digits behind the comma, all other measurements to be considered 1 digit behind the comma. Measurements must be within their maximum or minimum values under all Circumstances.

5.1. TYRES/Rims:

Tyres must be black, except for writing on the side wall (exceptions only after EFRA agreement). Foam and/or rubber tyres can be used. Treatment of tyres with any type of additive is strictly not allowed.

TYRE DIMENSIONS FOR 1/8th: :Maximum width of rear tyre: 64.0 mm.

TYRE DIMENSIONS FOR 1/10th: :Maximum width of front & rear tyre (across side-walls): 31.0 mm.

5.1.1 SPECIFICATIONS FOR CONTROL TYRE

Definition of Control Tyre: 1 set (front and rear), 1 brand, 1 diameter front, 1 diameter rear, 1 shore for front and 1 shore for rear.

A Control tyre is mandatory for: Controlled time practice (which are used for seeding), Qualifying, Sub-finals and final.

Price will be fixed for all EFRA season and will be revised in each AGM:

Price for 2018 1/8th: **20€** per set

Price for 2018 1/10th 200mm: **12€** per set

Diameters for 1/8th: 69.0mm front and 76.0mm rear

Shore hardness for 1/8th: 32 front and 35 rear (final number of shore after consultation with the organiser).

Diameters for 1/10th: 62mm front, 64mm rear

Shore hardness for 1/10th: 37 front and 40 rear (final number of shore after consultation with the organiser).

PROCEDURE FOR CONTROL TYRE (specific rules for drivers): -

- Only EFRA chosen supplier controlled tyres can be used (Hand-outs).
- Reused tyres will be allowed.
- When entering, drivers must order quantity of tyres that they want to use during the Official event: Minimum set tyres to order will be 5 sets and no maximum. Also, drivers should inform the number of tyres for free practice they want to get, so the Official Tyre Supplier can provide enough tyres for whole event
- When drivers arrive at the track, they will have their Officials sets (ordered at time of entering) ready in a specific box in race control. Sets ordered for free practice will be ready to collect in the Official Tyre Supplier area.
- Drivers must pay for sets that they ordered directly at the track to the Official Tyre Supplier. For extra sets that drivers want to order for the Official Race, a ticket system will be used. Drivers will have to pay for tickets to the

- Official Tyre Supplier and they must give those tickets in the controlled area. Officials will put new sets in a specific box of the driver
- If the hand out tyres have any visible defects (bad gluing, visible damage to tyre or rim) the effected tyre(s) can be exchanged before the official race start by race control. Production tolerance (including shore hardness) will not be considered as a defect. Tyres must be used as they are supplied and will be given out and fitted in the controlled area. (no modifications to the rims, except the hole for the axle, no shore meters can be used to select tyres).
 - During their race time, drivers can use tyres from their box in the controlled area. After finishing their race time, drivers must leave their tyres in their box and leave the pit area without tyres. If any tyre leaves the pit, it cannot be used in the Official race anymore.
 - When drivers finish their participation in the event, they can collect their used or unused tyres from the controlled area and keep them
 - For free practice, drivers have free choice of tyres used, but no treatment is allowed. From the start of the controlled timed practice, drivers have to use the Hand-out tyres
 - In case of rain (decided by the Race director after consultation with the Section Chairman), any alternative tyre can be used which has not been treated in any way, with the aim to get more or less traction.

PROCEDURE FOR CONTROL TYRE (specific for manufactures/brands):-

- Only EFRA registered manufactures/brands allowed to be Official Tyre Supplier. They must be registered at the Official Tyre Supplier list before 31st of March
- Requirements to be Official Tyre Supplier for EFRA events:
 1. All manufactures/brands must be Associated Member in EFRA.
 2. They must have enough capacity to provide necessary amount of tyres for EFRA events.
 3. Official Tyre Supplier has to be completely in charge of tyre distribution of tyres. This means: provide tyres directly at the track, take care of all regarding payments (they will accept cash and recommended credit card payments), handling Official tyres together with organiser (except controlled area), prepare ticket system and, in general, all minor things needed for the Control Tyre system.
- Manufactures/Brands as Official Tyre Supplier have the right to:
 1. To make any promotion by themselves as EFRA Official Tyre Supplier.
 2. To get enough space on the track during EFRA EVENTS to handle all necessary regarding Control Tyre System.
 3. To put banners on the track as EFRA Official Tyre Supplier with a maximum of 5 banners. If more banners on the track or another kind of advertisement, that will be in agreement with the organiser.
 4. To get all benefits for EFRA Associated Members.
- After 31st of March a final list with the Official Tyre Suppliers will be published on the EFRA webpage. In that list, Official Tyre Suppliers will get races according to a rotation list. (Special Remark for the first year: Manufactures/brands will get races according to the date joined as Official Tyre Supplier, meaning: The first race will be for the first company to join as OTS, second race will be for second company and so on..). Rotation list means: First company in the list get first EFRA event. Then, this company goes back to the list, the next one will get the next EFRA event, and then

- go back to the list, and soon...
- In the years when there is an IFMAR WC in the EFRA Bloc, all EFRA races at the WC track (Warm up, EFRA GP series...) will be done with the same tyres selected for the IFMAR World Championship.
 - If needed, EFRA will provide information about track preparation which will be mandatory for the event.
- 5.2. Fuel may only contain methanol (methyl alcohol, CAS number 67-56-1), lubricating oil, a small content of anti-corrosion chemicals and maximum 16% of nitro methane (Cas number 75-52-5) in volume. The specific gravity of the mixture may not be heavier than 0.87 grams/cc at 20°C and standard atmospheric pressure. For quick testing a Nitromax 16 can be used, but in case of failure with the Nitromax an official density meter must be used to control the specific gravity of the fuel including the temperature recorded during the test. A specific table will be produced to report the density (gm/cc) based on the temperature (from 0 to 50°C). The tolerance on the measurement will be +/- 0.5% based on the data reported in density table. Any violation with fuel which means any proof of the use of other additives as mentioned will mean 5 years of disqualification from any EFRA and IFMAR event.
 - 5.3. All vehicles must be equipped with brakes and a clutch in such a manner, that the vehicle may be held stationary with the engine running.
 - 5.4. Each motor must be equipped with an exhaust system and inlet silencer (INS-box) to reduce the amount of noise. A Registered muffler and Homologated INS-BOX is mandatory. In case of rain and on instruction of the Race Director, drivers can use something else as an INS box (In this case the INS box is not mandatory). EFRA's definition of a noise level is always final. Any modification to the muffler or INS Box is forbidden.
 - 5.5. Only EFRA registered mufflers are allowed at EFRA sanctioned events. The EFRA registered number must be engraved on the sidewall of the muffler. The tail pipe must be oriented on or below the horizontal Race directors have the right to measure at track side and take out cars that make too much noise. EFRA's definition of a noise level is always final. For 1/8th, a 3-chamber muffler is mandatory. For 1/10th a double chamber design, including silencer chamber, must be fitted.
 - 5.6. The aerial must be flexible. Carbon, metal, etc. is not allowed.
 - 5.7. The body and spoiler must be made of a flexible material and be painted properly. All windows must remain clear or be semi-transparent. When initially entered in a meeting the body must be neatly finished.
 - 5.8. The minimum weight limit of the cars:
 1/8th Class: 2400 grams for 4WD cars, 2300 grams for 2WD cars.
 1/10th Class: 1650 grams.
 For both Classes: The weight limit will be checked with the cars ready to race but with empty fuel tanks and with transponder (personal or with battery). The weight will be checked on a digital scale balance and can be done before the start of the heat, sub-final, final or after the end of either. If the weight is found to be under the minimum weight the driver will be disqualified from the heat, sub-final or final.
 - 5.9. Baseboard for checking the width of the car.
 1/8th Class: The car shall be measured for width by placing it on a baseboard equipped with two side rails of minimum 40.0 mm height spaced 267.0 mm apart and a length of 637.0 mm for Formula and Sports cars and 610.0 mm for GT cars which includes provision for checking the maximum height.

1/10th Class: The cars shall be measured for width by placing it on a baseboard equipped with two side rails of minimum 40.0 mm height spaced 200.0 mm apart and a length of 460.0 mm x 175.0 height (incl. 10 mm spacer).

For both Classes: Base-board and rails must be constructed of high quality board suitably stiffened to prevent distortion. The car must roll freely between the side rails with any steerable wheel set in the straight ahead position without any part of the wheels, bumpers, body shell or any other part of the car touching the side rails irrespective of the compression or extension of the suspension. Measurement of the wheel base may be made by simple measurement of axle centre distance, but Race Directors should be prepared to make more exact checks in case of doubt or protests.

It is suggested that the wheels are removed and the wheel spindles firmly placed on V-blocks whilst accurate measurements are made. It is the responsibility of the driver to ensure that his car complies with the regulation at all times when it is on the track and the organiser may check any car for compliance with the regulations at any time during the race meeting. If a car is found to exceed the limits of dimensions on checking immediately after a race, positive proof of race damage may prevent disqualification.

5.10. Checks at the technical inspection:

- a) Before the race all cars will be checked and during the heats the following random checks will be made:
 - Weight limit.
 - Muffler & motor.
 - Body and wing/spoiler.
 - Overall dimensions.

The chassis is to be indelibly marked before the race and if a driver wants to change it, he must present the new and the old to the inspection officer.

During sub-finals, all cars moving up to the next final plus the next one are to be checked. In addition to the above mentioned checks the following are to be done during sub-finals:

- Weight limit.
- Muffler.
- Body and wing/spoiler.
- Overall dimensions.
- Marking of the chassis.
- Fuel tank capacity.
- The same checks must be made after the Main Final for the top 4 places

5.11 Only two (2) servos are allowed.

5.12 It is not allowed to use any electronic parts for "Traction Control and/or braking control (ABS)" which can control the power of the transmission by means of a feedback system. It is not allowed to use any form of telemetry with active transmission.

5.13. List of approved equipment: All lists of approved equipment (i.e. bodies, mufflers and batteries) must be available on EFRA's webpage from the 1st of March every year. This is the final list for that year and no changes will be made before the next year. Equipment registered and homologated during the year will not be put on the list until the 1st of March next year.

6 1/8th CLASS TECHNICAL SPECIFICATIONS.

- 6.1. The engine may have a total capacity of not more than 3.50 cc. A maximum carburettor diameter of 9.00 mm.
- 6.2. The fuel tank including filter and fuel pipes up to the carburettor may hold a maximum of 125.00 ml. No loose inserts allowed. Any tank found illegal (>125 ml) after a heat or final shall be removed from the car and inspected for a second time after an initial "cool down period" of approx. 15 minutes. This period of 15 minutes is only necessary if ambient temperatures are above 20° C.
- 6.3. Overall dimensions of the car:
- Wheel base: 270.0 - 330.0 mm, overall width max. 267.0 mm
 - Overall width of the body max.: 267.0 mm, measured on top of the wing and on top of the sides and the lower front side.
- The lower sides between the two front and rear wheel arches will not be taken into account for technical inspection as long as they are not wider than 277 mm. If the body is wider than 277 mm on the lower sides the technical inspection has the right to take action with a warning for the first occurrence but disqualification from the race result for any further occurrences. For all finals: bodies must first pass technical inspection for verification and a first warning is not applicable.
- 6.4. Rims: The rim must not exceed 54.0mm. An edge to reinforce the rim on the inside (car-side) of 2.0 mm thickness and 3.0 mm height is allowed, flange diameter max. 60.0 mm. Any fixing bolts or other equipment installed in the wheel rims may not extend beyond the exterior of the wheel rim.
- 6.5. The front of the vehicle must be equipped with a bumper in such a manner, that it will minimise an injury if it makes contact with other participants or members of the public. The bumper must be made from a flexible material with all corners and sharp edges radiused. The contour of the bumper will follow the contour of the body with which it is being used. At no point may the bumper protrude more than 5.0 mm in front and 13.0 mm on the sides of the body.
- 6.6. If a rear bumper is fitted it must finish not more than 50.0 mm behind the rear axle.
- 6.7. All EFRA sanctioned events will be raced with open/closed cockpit prototypes/ sportscars/ can-am type/GT-P's/Group-C or similar cars. All lists of approved equipment, (i.e. Bodies, mufflers and batteries) must be available on EFRA's website from the 1st of March every year. These are the final lists for the year and no changes will be made before the next year. Equipment homologated/ registered during the year will not be put on the list until 1st of March next year.
- 6.8. A realistic driver figure (minimum 3 colours) made to 1/8 scale must be fixed in the correct position in open cock-pit cars. The windscreen and windows must be translucent (i.e. Not completely painted-in).
- 6.9. All bodies must have the front and rear wheel arches cut out if the original was so designed.
- 6.10. CUT OUTS
CUT OUTS -the windscreen must not be cut out. One hole of max. 6.0 sq. cm for cooling is permitted-side windows and rear windscreen may be removed..It is not allowed to bend windows to the outside - all parts of the vehicle must be covered, except:
- a) Cooling head of engine.
 - b) Air filter.
 - c) Aerial (max. 10.0 mm).
 - d) Outlet pipe of muffler.

- e) Fuel filler cap.
- f) Roll-over bar.

Only if these parts are extending the body. Cut-outs for above mentioned parts are to have no more than 10.0 mm clearance. In addition to this, the following holes are allowed:

- g) For muffler outlet.
- h) For fuel filler cap (50.0 mm maximum, round, viewed from above, or oval 40 mm x 60mm maximum). Note: Hole for roll-over bar and fuel filler cap can be combined. It's not allowed to combine fuel filler cap with Air filter hole and/or cooling head engine hole.

The following rules refer to the GT-P/Group-C body: In case of the Proto types or open cockpit cars, a clearance of 10 mm around the fuel filler cap is allowed.

- i) For radio switch (max. 10.0 mm)
- j) For glow plug (max. 20.0 mm).
- k) Fuel mixture valve (max 15.0 mm).

6.11.

Specific body attributes:

- a) Group C: Cars eligible for this class are those that have been used under "Group C" rules in the FISA Sportscar World Championship.
- b) GT1/GT2-Cars: Cars eligible for this class are those that are or have been racing in FIA GT Class. This can be either GT1 or GT2 cars like McLaren F1, Porsche 968 GT1, Ferrari F40, Marcos etc. The cut-out of the body at the rear is free after the rear axle, but rear lights must be fitted if the original is equipped with these.
- c) GT-P cars, eligible for this class are those that are or have been racing in the FIA "GT-P" class (see Le Mans 1999), or the Petit Lemans Series in America.
- d) Proto type CAN-AM cars: eligible for this class are those that are of have been racing in any official championship.

Homologation procedure: For all types of cars, the body shape behind the rear axle is not subject to control. The outer edge of the wheels must be covered at the centre of the axles viewed from the top. All bodies must be homologated by EFRA. The homologation number of the body must be visible, during the painting it will be possible to maintain transparent or semi-transparent the EFRA number.

6.12.

Wings and Spoilers:

Separate wings and spoilers are not allowed. Only a Gurney strip mounted on the rear of the body is allowed. The 'Gurney' should not be higher than 5mm with a 90 degrees angle (see drawing). Maximum height for the body, side and rear wing is 170mm with the chassis raised on 20 mm blocs. This maximum height with the Gurney Strip is 180 mm on a 20 mm spacer.

The maximum overhang is 100 mm measured from the rear axle centre point. See drawing.

Maximum dimensions: Group "C", GT-P, Can-Am, GT1 and GT2 cars max. width: 267 mm max. height: 170 mm (on 20 mm blocs) Overall, maximum height including a Gurney strip 180 mm (on 20 mm blocs) max distance behind rear axle: 100 mm (110 mm for 2wd & flat chassis cars).

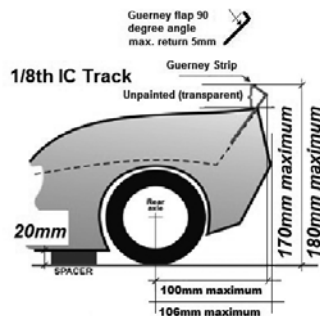

- 6.13. 4WD cars can be used without any technical restrictions except those listed in Section 5. The use of separate front wheel brakes, except through transmission is also not allowed (locking of a one-way bearing is allowed).
- 6.14. A roll bar may be fitted which must not project more than 30 mm above the cooling fins or roof, in case of, for instance a saloon car.

7 1/10th CLASS TECHNICAL SPECIFICATIONS:

- 7.1. The engine may have a total capacity of not more than 2.11 cc. Engines will be air-cooled, with front rotary valve, two-stroke induction. The engines may have a maximum of four (4) ports in the liner, including the exhaust port, seen with the piston at lowest position. No form of forced induction is allowed. No form of variable port timing.

Only glow plug ignition is allowed. One additional gap in the bottom (skirt) of the piston is allowed. No additional holes in the piston are allowed. Additional slits or holes in the liner for cooling purposes are allowed as long as they do not reach the top of the piston at lowest position. Standard and conical glow plugs are allowed. Reference to 'hole' in this rule means any hole that is surrounded completely by material.

- 7.2. Engine internal modifications are allowed as long as they are within parameters of rule 7.1.
- 7.3. A maximum carburettor diameter of 5,50 mm.
- 7.4. The fuel tank including filter and fuel pipes up to the carburettor, may hold a maximum of 75.00 ml. No loose inserts allowed. Any tank found illegal (>75.00 ml) after a heat or final will be removed from the car and inspected for a second time after an initial "cool down period" of 15 minutes. This period of 15 minutes is only necessary in case the ambient temperatures are above 20°C.
- 7.5. Overall dimensions:

	Min. (mm)	Max. (mm)
Wheelbase:	230.0	270.0
Width without body:	170.0	200.0
Width with body:	175.0	205.0
Length incl. body & wing:	360.0	460.0
Height of the top of the roof (measured with a 10 mm spacer under the chassis plate level):	20.0	175.0
Wing width incl. side dams:	125.0	200.0
Wing:		55.0
Side dams:		35.0 x 50.0
Wing overhang (at rear):		10.0.
Wheel dia. (measured at tyre bead location):	46.0	50.0
Wheel width (incl. tyre bead) and tyre width (across side walls):		
Front:		31.0.
Rear:		31.0

Although the wheel dia. at tyre bead mounting location must not exceed 50.0 mm diameter, an edge to reinforce the rim of 2.0 mm thickness and 3.0 mm height is allowed, giving an overall wheel diameter max. 56.0 mm

- 7.6. Wheels must be fixed by a screw or nut. The screw or nut installed in the wheel rims may not extend beyond the exterior of the wheel rim. Quick change wheel systems are not allowed. No automatic / spring charged or electric system to change the wheels is allowed (only manpower).
- 7.7. The front bumper must follow the body contour and must be constructed so as to minimise injury that may result from being hit by a car. The bumper must be

- made from foam rubber or a flexible plastic material.
- 7.8. Bodies: Bodies must be a 1/10th scale touring car in character, their design being inspired by vehicles that exist or have existed, and must comply to the GLOBAL BODY SPEC 1/10th IC Track. Bodies need to be sent to the Bodysell Homologation Officer for approval as indicated in appendix 9. The EFRA Registration Number has to be embossed in the body at an edge of the front window.
- 7.9. The rear of the body may not be cut higher than 50.0 mm measured with a 10.0 mm spacer under the chassis plate when level.
- 7.10. Details of all; front and rear lights, grills, air intakes and windows must be clearly contrasted from the surrounded paintwork. No parts of the car except the muffler outlet may protrude outside of the body shell, when viewed from above. No parts of the car except the antenna, body posts, transponder, may protrude outside the body shell, when viewed from the side wall. No additions or reshaping to the original moulded body shell (no body stiffeners allowed).
- 7.11. Cuts outs:
Only the following holes and sizes are permitted in the body shells:
- Maximum two holes may be cut with a maximum diameter of 60.0mm each. **Note:** holes may not be combined. Minimum distance between holes: 5,0mm.
- A hole with max. diameter of 35.0mm is allowed just above the engine cooling head for easy glow plug access but cannot be combined with any other hole, minimum distance between holes: 5.0mm.
- Both front side windows and rear window can be removed for ventilation, but not the side rear windows, which must remain intact. Small holes can be made for the body posts, transponder, carburettor adjustment and radio antenna (max. dia. of 10mm).
- The hole for exhaust pipe must be of reasonable size.
- No other holes are permitted.
- 7.12. Wings and spoilers:
- One wing and one spoiler may be mounted to any car (if the original full-size car had more, it is allowed to do the same). Wing and spoiler must be made from a flexible material.
- Wing and spoiler may not be fixed to body with piano wire (they must be mounted directly to the body).
- Wing and spoiler must not protrude outside the maximum height and width of the body (incl. the side dams).
- Rear wings must be mounted in the same place as was intended by the body manufacturer. The overhang must not exceed 10 mm at the furthest point, measured from the most rear point of the body.
- Side dams may be fitted but must be a reasonable representation of those fitted do the original car, fit in a rectangle with the measurements defined, and must not project above the height of the roofline.
- The height of the wing may be adjusted but the wing, incl. side dams must not extend higher than the roofline.
- Wings (excl. side dams) are to be of single moulded construction (no flat packs/bend your own).
- 7.13. 4WD and 2WD cars can be used without any technical restriction except those listed in Section 7. The use of separate front wheel brakes, except through trans.
- 7.14. Roll bars (roll over bars) must be kept under the body.

8. A & B LICENCE:

- 8.1. To qualify for an "A" licence, a driver must be placed 1-25 in the EFRA ranking system. (All other drivers will be classified EFRA "B" licensed). These drivers must be approved by their own National Association as having sufficient experience and skill to take part in an International competition. World Champion will retain "A" licence for the next 2 years. European Champion will retain "A" licence for the next 2 years. European Champion B-driver will retain "A" licence for the next 2 years. The EFRA ranking list is based on the overall result in the EFRA GP series during year in progress. The total result of this list will decide upon A and B licence. For all the races involved in this ranking, points can be achieved for the result after the finals (see General rules points table section 3.3.6).

9. PENALTIES

- 9.1. Referees must issue a verbal blue flag warning to slower drivers or to make drivers that are not within the same lap as the car that is about to pass him, to make way and not to obstruct the passing car. This warning must be announced "ATTENTION DRIVER (Name)".
- 9.2. Failure to respond to the verbal blue flag will result in an official warning and the driver must make a mandatory pit-stop for 10 seconds. During this mandatory stop the Referee will administer the official warning directly to the driver. In the case that there is no possibility to call a driver for a stop and go penalty, the Referee and/or Race Director will announce a time penalty of 10 seconds.
- 9.3. Any driver who is given 2 (two) official warnings will be immediately disqualified from the race in progress. After 3 (three) warnings the driver will be disqualified from the entire event.
- 9.4. Deliberate waiting for other cars will be treated as a verbal blue flag offence and a "Stop/Go" penalty issued. The Referee will advise the driver that his behaviour has been noted and that he should race normally. Failure to follow the Referees instructions will result in immediate disqualification. In the case that there is no possibility to call a driver for a stop and go penalty, the Referee and/or Race Director will announce a time penalty of 10 seconds.
- 9.5. Deliberate obstruction of other cars in an attempt to influence the result of a race will lead to immediate disqualification and loss of his/her International Licence until after the next event of the same kind. (e.g. GP/EC/WC).

10. 10. GT TECHNICAL RULES

2 Basic versions, with a lot of differences. Italian rules with no scale bodies and wing incorporated and a lot of technical allowance. International rules, based on real off-road cars with scale bodies, separate wings (like large scale and electric touring car) and technical limitations (more standard).

	GT Cars, Italian Rules	GT Cars International / Roar Rules
General	GT/Rally cars with IC motor, 2WD or 4WD. Basic car was Off-Road, but drive train is different.	GT/Rally cars with IC motor, 2WD or 4WD. Basic car is Off-Road, with drive shafts, no belts allowed.
Manufacturers	There are a number of Italian brands for this class available and a single one outside Italy.	There are a number of International brands available from this type of car.
Dimensions	Length overall 730mm	Length: TBD
	Minimum width 290mm	
	Maximum width 310mm	Maximum width 310mm
	Wheelbase between 270-330mm	Wheelbase between 270-379mm
	Maximum height 340mm including wing with suspension fully compressed, chassis against the floor.	Maximum height 250mm including wing with suspension fully compressed, chassis against the floor.
		Wheels Mounting Bead diameter: Maximum: 79.00 mm / 83.50 mm. Overall Diameter Maximum: 88.50 mm. Width Maximum 44.45 mm. Tyres Diameter Maximum 119.22mm. Minimum 109.22 mm. Width Maximum 47.0 mm
Weight	4WD 3500 gram, 2WD 3400 gram	4WD 3500 gram
Clutch		Only buggy based 2, 3, or 4 shoes systems No radial type clutches (Centax)
Transmission	The transmission can be 2 or 4 wheel drive and must be mechanical (universal joints, belts, chains, etc.) Allowed is a gearbox with maximum two speed. It's forbidden to use one-way drive axle. The cars must be equipped with front differential axle and rear differential axle, which cannot be locked.	Any 1/8 scale Buggy or Truggy based shaft driven nitro powered vehicle. (off-road conversion is OK) with front kick up. Chassis with Kick up cannot be altered to change original manufacturers design. Stock and factory optional chassis are permitted, but it must retain all the characteristics of the standard off-road chassis on which it's based. Chassis must be identical to their off-road counterparts in all dimensions except where it's necessary to convert the chassis for on-road use. Carbon fiber chassis are not permitted.

	GT Cars, Italian Rules	GT Cars International / Roar Rules
		<p>Transmission: Single speed or two-speed only. Single speed configurations must include a solidly mounted spur gear to a standard bevel gear centre differential or a solid spool (no one-way bearing). No other differential types will be permitted. Two-speed transmissions must use an automatic centrifugal shifting mechanism that is not remotely adjustable or programmable. Because of the nature of the two-speed transmission design, no centre differential is required, but the transmission must include a solid centre shaft that doesn't allow differential action between the front and rear drive assemblies</p>
		<p>A shaft-drive system with two gear-type open differentials are required. No one-ways, spools, locking "Torsion-type," or externally adjustable differentials are permitted. The gear diffs. can be tuned only with the use of silicone-based fluid. Identical F/R drive ratios are required—no F/R underdrive/overdrive permitted. A single speed mounted to a centre spool, or an included two-speed transmission are permitted. The drivetrain shall be a centre shaft system with ring and pinion gears driving the differentials. Shaft-drive only—belt drive cars are not permitted. The drive system must maintain the same features as used in the original off-road configuration except where noted, including the centre differential/two speed transmission with separate front and rear centre drive shaft's</p>
Body	<p>All models must be fitted with a 1/8th scale body that is similar of a car really existing with the exception of open cockpit cars. Allowed are replica's from ALMS, GT1 or GT2, Super GT, DTM, and V8 Supercar Cars. No homologation required, but EFRA can refuse bodies which are not within the spirit of this class. The body must be fixed on the integral parts of the chassis. The bodies must be made of flexible material and painted. No part of the model can protrude from the body with the exception of the roll bar.</p>	<p>Any commercially available factory licenced replicas of ALMS, GT1 or GT2, Super GT, DTM, and V8 Supercar Cars. Any GT like body.</p>

	GT Cars, Italian Rules	GT Cars International / Roar Rules
Openings in the body	<p>Opening fore exhaust tail (pipe hole not exceeding 8 cm square cm on one side of the body). Openings for radio antenna (maximum diameter 10mm), spark plug (maximum diameter 25mm), carburettor (maximum diameter 10mm). The Cooling head of the motor must remain completely inside the body. One Hole with a diameter of 50mm maximum for refuelling. It is allowed to have one opening in the front and rear with a maximum diameter of 50.0 mm each. Side window on each side can be removed. The windows cannot be folded outwards to get more air to the engine. It is also not permitted to have a system under the body for conveying air inside the body. All bodies must have the front and rear wheel arches removed.</p>	<p>All wheel wells must be cut out and rear of the bodies should maintain tail lamps and cannot be completely cut out. No wedge style Bodies. All body approvals will be subject to scrutiny of the respective or collective advisory committees regarding compliance to the "spirit of the rules." An objective evaluation shall determine the status of each submission based on the adherence to the said rule. Bodies must be factory licensed replicas of the aforementioned street or race cars, but no "race-only" bodies are permitted. Bodies based on Daytona Prototypes, or the odd Super GT cars that are not representative of a commonly available street car, are not permitted. Bodies must include full front and rear fascia's, and conform to the rules herein that limit openings in the body for the purposes of refuelling, starting, engine tuning, and antenna holes</p>
Wing	<p>The wing must meet the following requirements: Must be mounted on the body. Depth: 77 mm maximum, measured parallel to the inclination of the wing. Width: 310 mm maximum, measured parallel to the inclination of the wing.</p>	<p>Bodies must be fully detailed in order to compete in EFRA competition. The body must have visible window, body panel and trim markings, and the windows must be mostly clear. Some intrusion for creative painting purposes and tinting is permitted, but the windows must be transparent.</p>
		<p>Rear Wing Side dam Length Maximum: TBD. Height Maximum: TBD. Chord Maximum: TBD. Width Maximum: 217 mm</p>
Bumper	<p>All models must be equipped with bumpers made of flexible material, with no sharp edges and rounded, so as to minimize the consequences of a possible impact with the model. All models must be mounted on the front bumper a bumper that protrudes from each bumper. The complete bumper, must remain under the silhouette of the body.</p>	
Tank	<p>The tank can have a maximum capacity of 125.00 ml including filter and hose connection to the carburettor.</p>	<p>Up to 150cc max fuel capacity</p>

	GT Cars, Italian Rules	GT Cars International / Roar Rules
Fuel	The mixture may contain only methanol, nitro methane and lubricating oil with a maximum of 16% nitro and an SG of 0.87.	The mixture may contain only methanol, nitro methane and lubricating oil with a maximum of 16% nitro and an SG of 0.87.
Engine	The engine of the model car will have a total capacity of up to 3.50 cm ³ . The car must be fitted with an exhaust silencer system. Only 3 chamber EFRA registered mufflers can be used with EFRA registered INS boxes. The exhaust tailpipe must be directed towards the roadway or, at best, parallel to it.	Motor, 5-port 0.21, on or off-road based, 7mm carb. insert, internal modifications are legal. Pipes: EFRA List. Rubber extensions to stinger OK. No internal moving parts.
Brakes	Each model car must be fitted with clutch and brake system in such a way that it can be maintained stationary with the engine running. The brake must act on the transmission and must be of the mechanical type. The use of separate brakes on the wheels is not permitted	Only standard mechanical brakes are permitted – hydraulics are not permitted. Up to two brake discs are permitted anywhere on the centre driveshaft's. Brakes may not be located on the outboard axles.
Wheels, tires	The wheels, front and rear, must have a diameter of 78 mm + / - 2mm. The maximum width of the tyre (rim + pneumatic) cannot be more than 43 mm. The tyres of cars must be only of black colour and may have lateral writing of different colours. The tyres must be from moulded rubber, the pattern is free. Inserts are allowed. Wheels must use a 17mm hex hub consistent with the dimensions and function of the hubs used in 1/8 off-road racing. The wheel must be fixed by a 17mm wheel nut, threaded on to the hex hub. Quick change mechanisms are not permitted. No tyre or rim may protrude outside the body. In all races a controlled tyre is mandatory with different/more brands	Wheels must use a 17mm hex hub consistent with the dimensions and function of the hubs used in 1/8 off-road racing. The wheel must be affixed by a 17mm wheel nut, threaded on to the hex hub. Quick change mechanisms are not permitted. Dish wheels are not permitted. No more than 30-percent of the face of the wheel may be solid. The wheel "face" will be defined as all areas of the wheel between the mounting bead and the centre mounting hole. Tyres must be "production" tyres – hand cut tyres or those not available to the general public are not permitted. "Available" is defined as having been sold to consumers a minimum of 30 days prior to the official start of the event. Tyres must be moulded rubber – no foam tyres are permitted in any class. A controlled tyre is advised. All races must be completed on the same tyres used to start each race (qualifying and finals). Tyre changes are not permitted except when a wheel and/or tyre are determined by the race director or a EFRA official, to be damaged. Excessive tyre wear does not constitute damage

	GT Cars, Italian Rules	GT Cars International / Roar Rules
Elec- tro- nics	It is not allowed to use any electronic devices with the exception of: The two radio channels of the receiver which will be used to operate steering, throttle and brakes. A battery to power the receiver with any voltage regulator and the transponder as well as cables, connectors and/or a switch.	
Techn- ical Exclu- sions	Not more than two (2) servos. It is not allowed the use of additional electronic equipment for the Traction Control or braking (ABS). It is not allowed the use of any active telemetry system. 4 wheel brakes, or Independent controlled braking on the front wheels is not allowed. Liquid cooled engines. Hydraulic systems. No body or wheel flares extenders allowed and no Lola, wedge or open cock pit style bodies are allowed. Carbon fibre chassis are not permitted. Treatment of the tyres with additives is prohibited. Competitors found to be using additives will be disqualified from the event. No chassis mounted or Buggy/Truggy type wings allowed	

11 1/8th ELECTRIC CARS

- 11.1. Car must be an 8th scale electrically powered character representation of a racing car within the given dimensions. Maximum width of car is 267 mm, this excludes the body shell which has it's own dimensional rules.
- 11.2. On all cars braking must be a combination of electronic speed controller and motor (dynamic braking) only via the single speed fixed transmission to the rear wheels.
- 11.3. All cars must be fitted with a failsafe device, this can also be incorporated into the receiver or speed controller.
- 11.4. 1/8 Scale Electric Track Cars will be driven by Lithium based batteries with a nominal voltage of no more than 15.2 volts (4S). It is allowed to use 2 x 2S or 4 x 1S. If multiple individual batteries are connected together (in parallel or series), then all batteries used must be of the same manufacturer brand and same Part Number.
 Only homologated batteries shown on the EFRA Approved Lists on the official EFRA website will be legal for use at EFRA sanctioned events.
 All Lithium Batteries must comply with the published data shown on the EFRA Approved Battery Lists. Batteries that are not compliant with the dimensional rules or published weights will not be allowed.

LiPo/LiFe drive batteries must be in a 'Lipo sack' at all times when being charged or discharged. This applies to any discharging procedures except during a race or when using organiser supplied resistors. Anybody not doing this will be penalised at the event. LiPo sack is defined as a receptacle designed for the purpose of charging LiPo/LiFe batteries and of a suitable construction as to contain a LiPo/LiFe fire.

The maximum charging cut-off voltage is 4.20v per cell in series (16.80v for 4S). Organisers can check this voltage at any time during the event.

All Rules concerning:- Technical Specifications, Race Procedures, Homologation Procedures, for Lithium Batteries can be found in NEW APPENDIX 4.

MODIFIED CLASS (4wd With Suspension)

- 11.5. Minimum weight to be 2500g (ready to race).
- 11.6. The brushless motor (Maximum 2800kv) and speed controller combination must be or have been previously commercially available and have a maximum recommended retail price (RRP) of 350 Euro including all taxes. The motor must have a 5mm pinion shaft.
- 11.7. Speed controller reverse operation must be disabled.

STOCK CLASS (4wd Without Suspension)

- 11.8. Fixed chassis cars without any moving suspension components.
- 11.9. Minimum weight to be 2200g (ready to race).
- 11.10. The brushless motor (Maximum of 2600kv) and speed controller combination must be or have been previously commercially available and have a maximum Euro recommended retail price (RRP) of 350 euro including all taxes. The motor must have a 5mm pinion shaft.
- 11.11. Speed controller reverse operation must be disabled.

BODIES

- 11.12. Bodies must follow same rules like 1/8th IC cars (see 6.7 to 6.9 Appendix 1).

CUTS OUTS

- 11.13. One cut out for cooling of motor / esc with max. 30x40mm. Any part of the body cannot be folded outwards to get more air to the motor. It is also not permitted to have a system under the body for conveying air inside the body.

WINGS AND SPOILERS

- 11.14. Wings and spoilers must follow same rule like IC cars (see 6.12 Appendix 1).

RACE FORMAT

11.15. QUALIFICATION

1. Heats must be separate between categories: modified and stock. If the number of drivers in one category is less than 10 drivers, all drivers racing in 1/8th electric class must race together and then, and results will be separated.
2. The Qualifying Heats will be 5 minutes and the last lap plus the time to complete this last lap up to a max of 40 seconds
3. 5 Rounds of Qualifying will be run, irrespective of the number of drivers. Qualifying will be 5 minutes + last lap
4. In Qualifying Rounds the Round by Round point system will be used (same system as IC cars, see 2.4 Appendix 1).
5. The qualifying heats will be a maximum of 10 drivers and where possible equal number of drivers in each.

6. Starting for qualifying heats will be from the start line or pit lane, using the staggered start system (one by one). In each Round, the order of starting Heats will be same as rule 4.2 Appendix 1.
7. The qualifying results will determine the composition of all finals with the top 10 proceeding to the "A" final and so on down.

11.16. FINALS

1. Durations for finals will be 5 minutes + last lap.
2. There will be 10 drivers in all finals where possible. Finals will be organized for all competitors. 3. If the lowest Final has less than 3 drivers, they will be mixed as equally as possible in the next Final, respecting their qualifying position for their start order.
3. If the lowest Final has less than 3 drivers, they will be mixed as equally as possible in the next Final, respecting their qualifying position for their start order.
4. The winner determined from the combined A finals will be the champion. If the A finals cannot be completed, the awards will be made based on the final Qualifying positions.
5. All finals will be run in 3 legs from slow to fast.
6. If three leg finals are run, then the best 2 out of 3 to count
7. The winner of a final gets 1 point; the second gets 2 points and so on up to 10 points for the 10th driver. In the event of a tie regarding time in a Final, the points will be equally awarded to each driver and the next driver not tying will be two points more.
8. In the event of a tied position the driver with the single highest finishing position in either of the best 2 finals that counted will be awarded the tie. In the event of a continuing tie then the laps and times from the highest finishing position will be compared. The driver with the fastest laps and time total will be awarded the tie. In the case of a continuing tie, then the times from the second-best position will be compared. When some drivers of a final do not run a final, they will be awarded the remaining points in the order of their car numbers.
9. Cars, which do not pass the start/finish line after the prescribed race time, will be classified according to the number of laps recorded. The "A" finalist with the lowest number of points will be the winner of the International Race.
10. All final results will be published at least 10 minutes before prize giving. 11. There will be awards at least for all "A" finalists, and the winners of any other final. If no round of Final(s) are completed the results of the event are taken on qualifying positions